

Our associates will ensure the tool works properly before you leave the store. If you experience issues with the tool while completing your project, simply bring it back to the Tool Rental Center to get a replacement. If you purchase Damage Protection at the time of your rental, you are not responsible for repair costs for tools that break due to normal use.



HARPER[®]

Straw Blower

Operator's Manual

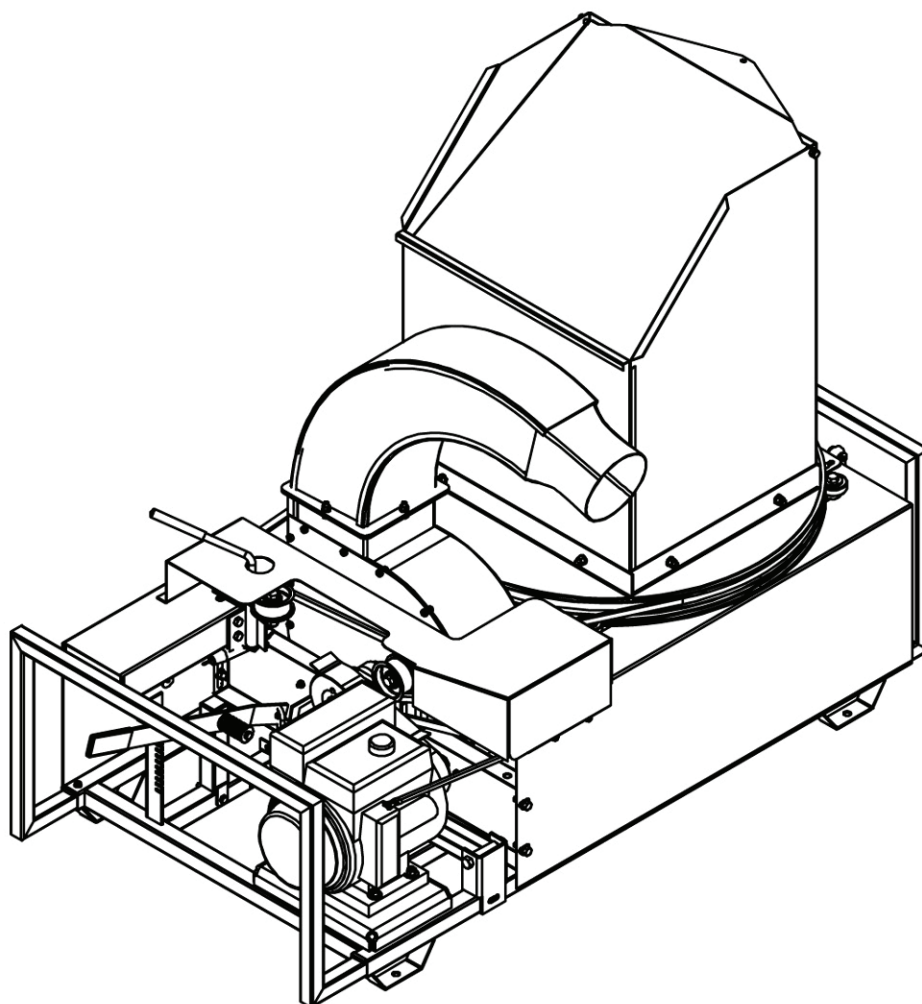

Model 1800



Thank you for renting a Harper Straw Blower.

As with all Harper products, the Straw Blower has been developed through tough design and testing procedures to produce a top quality machine. This manual gives assembly, operating, and service information for the models 1300, 1800, & 5400. Please read and understand all instructional material included with the Straw Blower or its components before assembling and operating the equipment.

A Straw Blower can present hazards to an operator who follows unsafe procedures in either the operation or maintenance of the unit. Therefore, **SAFETY WARNINGS** are presented at certain locations in the text.

THIS SYMBOL:  **SAFETY WARNING!** 

MEANING: Failure to understand and obey this warning may result in injury to you or others. Whenever this symbol is used, please pay very close attention to the information presented, and make sure you fully understand. If you do not, contact your dealer or Harper Industries, Inc. for clarification.

 **SAFETY WARNING!** 
ALL SHIELDS AND GUARDS MUST BE IN PLACE FOR PROPER AND SAFE OPERATION OF THIS EQUIPMENT. WHERE THEY ARE SHOWN REMOVED IN THIS MANUAL, IT IS FOR PURPOSES OF ILLUSTRATION AND INSTRUCTION ONLY. DO NOT OPERATE THIS EQUIPMENT UNLESS ALL SHIELDS AND GUARDS ARE IN PLACE.

Harper Industries, Inc. is continually striving to improve the design and performance of its products. We reserve the right to make changes in specifications and design without thereby incurring any obligation relative to previously manufactured products.

© 2012 Harper Industries, Inc.

The Harper name is a registered trademark of Harper Industries, Inc. All other brand and product names are trademarks or registered trademarks of their respective companies.

Table of Contents

OPERATOR SECTION	
To the Owner or Operator.....	1
	2
Table of Contents.....	3
Specifications.....	4
Control Identification	
Engine Powered Model	
Tub.....	5
Tub Engagement Lever.....	5
Engine.....	5
Safety Door.....	5
Hose Adapter (option).....	5
Cutting Knife Engagement Lever.....	5
Retractable Bale Rack.....	5
Safety Guidelines	
Gasoline.....	7
Guards & Shields.....	7
Safety Decals.....	7
Operation	
Engine Powered Models	
To Begin Operation.....	11
To Stop Operation.....	11

Specifications

Engine Powered Models: 1300 and 1800

Engine	4-cycle Honda or Briggs & Stratton gasoline engine
Horsepower Rating	1300 - 13 hp 1800 - 18 hp
Dimensions	Width - 31" Height - 51" Length - 55"
Weight	490 lbs (shipping weight 565 lbs)
Cutting Device	4 blade impeller - 16.5" diameter
Knives	32
Discharge	6" x 30' Super-flex hose or directional spout

PTO Powered Model: 5400

Drive	540 RPM PTO
Dimensions	Width - 31" Height - 51" Length - 60"
Weight	525 lbs (shipping weight 600 lbs)
Cutting Device	4 blade impeller - 16.5" diameter
Knives	32
Discharge	6" x 30' Super-flex hose or directional spout

Harper Industries, Inc. is continually striving to improve the design and performance of its products. We reserve the right to make changes in specifications and design without thereby incurring any obligation relative to previously manufactured products.

The Harper Straw Blower, in engine powered and PTO versions, chops and applies straw for erosion control, bedding and mulching. The depth of the cut is easily adjustable while in operation to handle a variety of materials* and conditions. The standard 30' hose provides even layering and pinpoint placement. The hose is pliable down to 20° F. Temperatures below 20° may cause polyurethane to crack when stretched. A 360° directional spout is available for broadcast operations.

***NOTE:** Do not shred cardboard with a Harper Straw Blower. The density of cardboard will cause damage to the cutting knives and the rotor.

Control Identification

Engine Powered Models

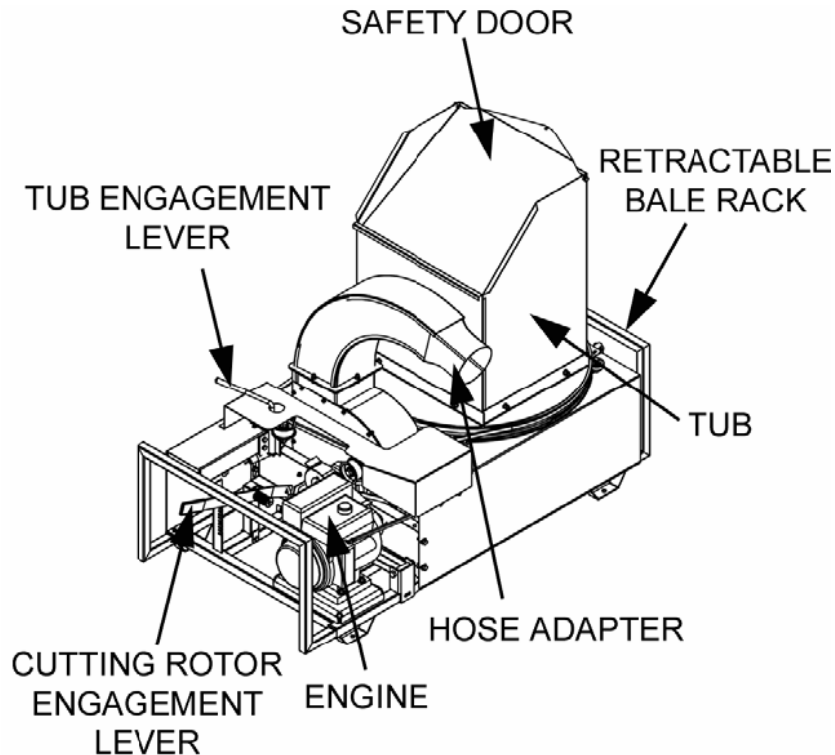

Tub – the tub secures the bale as it rotates and gravity pulls the bale down into the cutting knives.

Tub Engagement Lever – engages the rotation of the tub.

Engine – powers the Straw Blower.

Safety Door – the door on the tub is spring loaded to prevent objects from falling into the cutting knives, and debris from flying out of hopper when no bale is present.

Hose Adapter (option) – feeds the straw into the Super-flex hose. The direction spout may also be mounted in the same location.

Cutting Knife Engagement Lever – engages the cutting knives and controls belt tension.

Retractable Bale Rack – pulls out to hold an extra bale.

Engine – powers the Straw Blower.

Safety Guidelines

- Use genuine factory parts or parts with equivalent characteristics, including type, strength and material. Failure to do so may result in product malfunction and possible injury to the operator and/or others.
- If hardware is not secure, or if some of the hardware is over-tightened, equipment failure may result, posing possible safety hazards.
- To prevent possible eye injury, always wear SAFETY GLASSES while operating equipment.
- Replace locknuts and locking screws if you can tighten them without feeling considerable resistance for several turns before they are completely tight. Replace them with factory authorized parts or their equivalent.

Gasoline



Gasoline is extremely flammable and can be highly explosive.

- Always use an approved container for gasoline.
- Do not allow open flames or sparks while performing maintenance or refueling.
- Never remove the fuel tank cap or add gasoline when the engine is running or while it is hot.
- Never fill the fuel tank indoors (fumes can collect).
- Wipe up spilled gasoline immediately and completely.
- Do not store gasoline in a room with an appliance that has a pilot light to where electrical appliances or switches may cause sparks.
- Always store gasoline outside, in a safety can (a can which has a flame

arrestor and pressure relief valve in pour spout).

- Gasoline fumes are heavy and will sink to the lowest point, collecting and becoming more and more hazardous. 1 part gasoline in 20 parts air will explode easily and violently.
- Never store the equipment with gasoline in the tank inside a building where fumes may reach an open flame or spark. Allow the engine to cool before storing in any enclosure.
- Be certain to provide adequate ventilation if an engine must be run indoors - exhaust fumes are dangerous.

Guards & Shields

- Keep all safety devices in place.
- Replace all worn, damaged, unusable, missing or lost safety shields and guards before operating the equipment.
- Keep the equipment in good operating condition.

Safety Decals

- If safety related or instructional decals become illegible or are removed, replace them immediately. New decals may be obtained from your local Harper Dealer.
- If you replace parts that have such decals attached to them, make sure the decals are replaced with current versions, and are on the replacement parts before the machine is operated again.

Operation



SAFETY WARNING!



- **Wear approved eye and ear protection while operating the machine.**
- **Keep all guards in place during operation. Never operate machine with the tub removed.**
- **Before operating the machine, check to ensure that all the belt guides and snubbers are in place, to prevent belts from slipping off the pulleys and systems from being accidentally engaged.**
- **Check the bale tub for children, pets and foreign objects before operating.**
- **Never push material onto the cutters with your hands or feet.**
- **Periodically clean chopped material away from engines to lessen the possibility of fire.**
- **Always keep the fire extinguisher near the Straw Blower during operation.**

Engine Powered Models

To begin operation:

1. Make sure tub and cutting rotor are NOT engaged.
2. Fill fuel tank with gas.
3. Make sure the vent on the fuel tank is open at least a quarter turn. (If it is closed the engine will vapor lock and will not run). 1300 model has no manual vent.
4. Start the engine. Refer to engine manual for more information.
5. Engage the cutting rotor by pushing the rotor engagement lever down.
6. Place a bale into the tub.
7. Engage the tub rotation by moving the tub engagement lever towards the engine.

8. Add another bale when there is about 1/3 bale left in the tub.

To stop operation:

1. Stop the tub rotation.
2. Disengage the rotor mechanism.

PTO Powered Model

To begin operation:

1. Make sure the tub engagement lever is disengaged.
2. Engage the PTO, to start blade rotation.
3. Set the first bale into the tub.
4. Engage the rotor by turning the engagement lever to the front of the machine.
5. Add another bale when there is about 1/3 bale left in the tub.

To stop operation:

1. Disengage the tub.
2. Disengage the tractor PTO to stop rotor.

NOTE: The Straw Blower is gravity-fed and it is natural for the rate of chopping to slow as the bale becomes lighter and until another bale is added.

NOTE: If bales are bound by wire instead of string or plastic, remove the wire before putting the bales in the tub.

NOTE: On initial operation, the belts will become stretched and need readjustment after the first 10-15 bales. When adjusting belt tension, use a straightedge across the faces of the pulleys to make sure they are properly aligned and the belts run true.

CUTTING DEPTH

All Models

- The cutting depth is adjusted by moving a lever and putting it into the slot that gives the desired cutting depth. The adjustment is located at the rear of the machine.

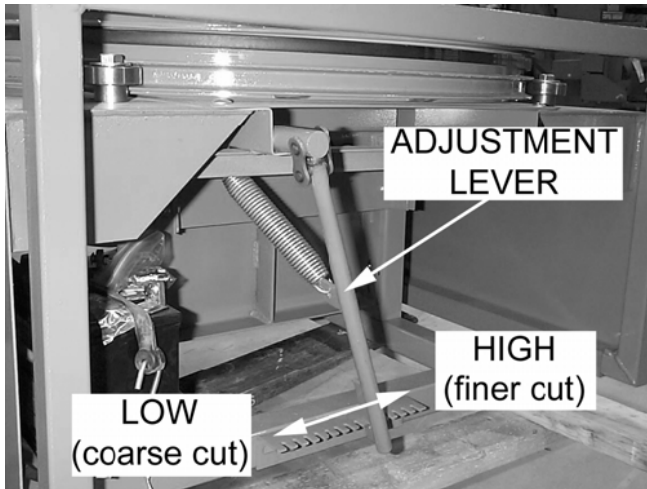

Troubleshooting

ENGINE

Problem:	What to Check:
Engine shuts off during operation	<ul style="list-style-type: none">• Engine may be low on fuel• Engine may be low on oil (The Honda engine is equipped with an “Oil Alert” automatic shut off)• Air breather may be clogged or closed.

BELTS

Problem:	What to Check:
Belts slip	<ul style="list-style-type: none">• Tension Adjustment• Load may be excessive• Knives may be too dull• Grate setting may be too low (cutting too deeply)• Foreign material may be lodged in the chopper (on knives or blower paddles)• Bearings may have seized
Belts wear rapidly, jump, catch or twist	<ul style="list-style-type: none">• Pulleys may not be properly aligned. Check with a straightedge across the faces of pulleys.

CUTTING AND DISCHARGE

Problem:	What to Check:
Hose plugs	<ul style="list-style-type: none">• Material being chopped may have too much moisture in it.• RPM may not be high enough. (540 RPM max is recommended for PTO model. Adjust throttle to increase RPM to required levels. DO NOT adjust engine governor on engine models.• Foreign material may be lodged in the hose• Grate setting may be set too low
Slow cutting time	<ul style="list-style-type: none">• Grate setting may be too high• Material being cut may be too wet• Knives may be too dull• RPM may be too low